

# AF47P & AF46 Series

*Antistatic Firesafe Three Piece Ball Valves*



CE

**Size Range:** 1/4" - 2 1/2" (8 - 65mm) - 3" & 4" available on request

**Materials:** Stainless steel, Carbon steel

**End Connections:** Screwed, butt weld, socket weld

**Application:** Chemical, Petrochemical, Oil and Gas, Refinery, Offshore, Emergency Shut-Off Valves

**Service :** Gas, Chemicals, Solvents, Fuels, Thermal Fluids

**Operation:** Manual or actuated

**Standards:** Firesafe to API 607 4th Edt., API 6FA and BS 6755 Pt 2

**Design Features:**

- Secondary metallic seating ring
- Secondary metallic stem seal
- Tongue & Groove body seal design
- Antistatic stem device
- Larger threaded body bolts in stainless steel

# Specifications

## Material Specifications 1/2" - 2 1/2"

ITEM	DESCRIPTION	MATERIAL	QTY.
1	BODY	STAINLESS ST. ASTM A351 CF8M CARBON ST. A105 / WCB	1
2	END CONNECTOR	STAINLESS ST. ASTM A351 CF3M CARBON ST. A105 / WCB	2
3	BALL	STAINLESS ST. ASTM A351 CF8M	1
4	STEM	STAINLESS ST. ASTM A276 316/316L	1
*5	SEAT RING	VIRGIN PTFE, GLASS FILLED PTFE NRG, PEEK	2
*6	BODY SEAL	EXPANDED GRAPHITE IMPREGNATED GRAPHITE	2
*7	STEM THRUST SEAL	25% CARBON FILLED PTFE	1
8	STOP PIN	STAINLESS ST. ASTM A582 303	1-2
*9	STEM PACKING	EXPANDED GRAPHITE IMPREGNATED GRAPHITE	1
10	FOLLOWER	STAINLESS ST. ASTM B783 316L	1-2
11	DISC SPRING	STAINLESS ST. 17-7PH	2
12	STEM NUT	STAINLESS ST. ASTM A194 316	1
13	LOCKING CLIP	STAINLESS ST. ASTM A164 304	1
14	HANDLE	STAINLESS ST. ASTM A240 430 CARBON STEEL, ZINC PLATED	1
15	SERRATED WASHER	STAINLESS ST. 410	1
16	HANDLE NUT	STAINLESS ST. ASTM A194 316	1
17	BODY BOLTS	STAINLESS ST. A2-70 DIN 912	8
18	HANDLE SLEEVE	VINYL PLASTISOL	1
19	ANTISTATIC SPRING	STAINLESS ST. AISI 302	1
20	ANTISTATIC BALL	STAINLESS ST. AISI 304	1

\* STANDARD ITEMS FOR REPAIR KITS

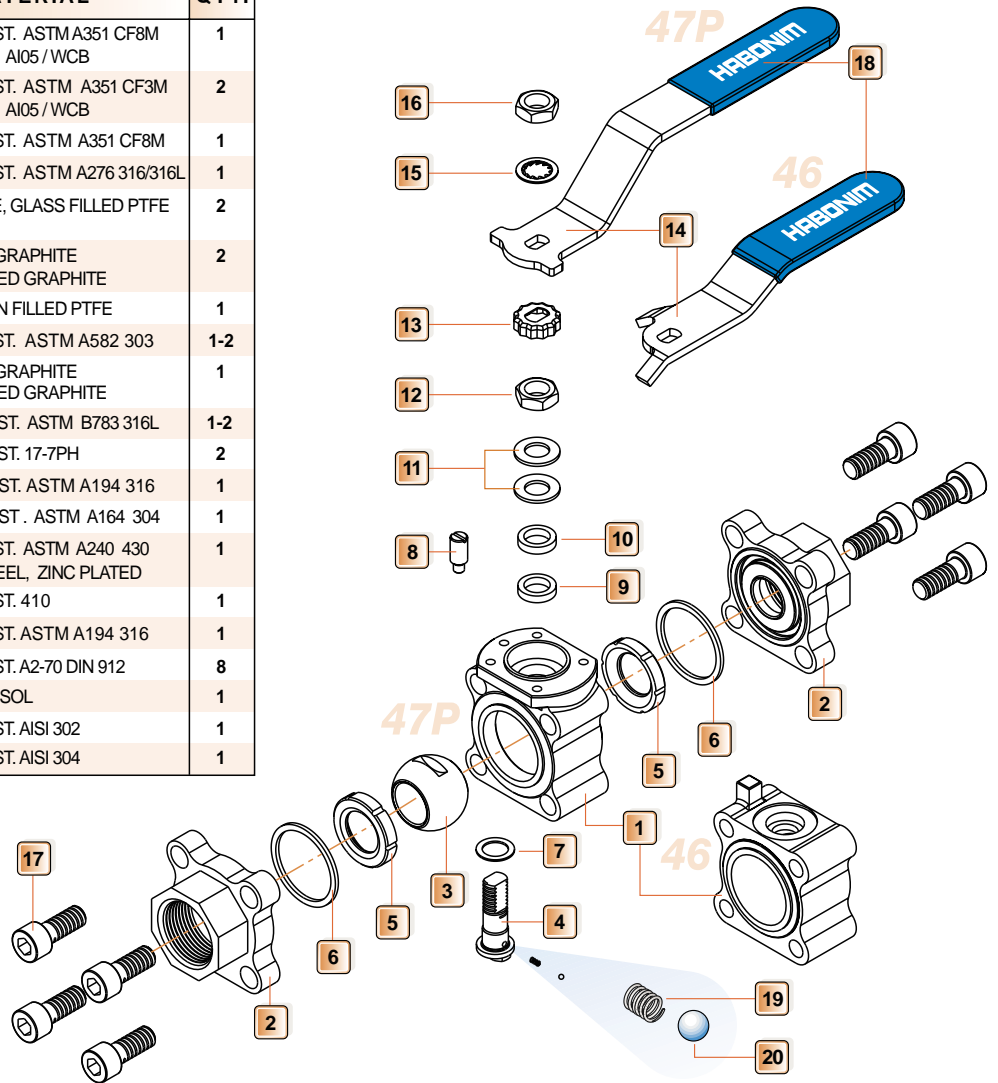

### Pressure / Temperature Rating

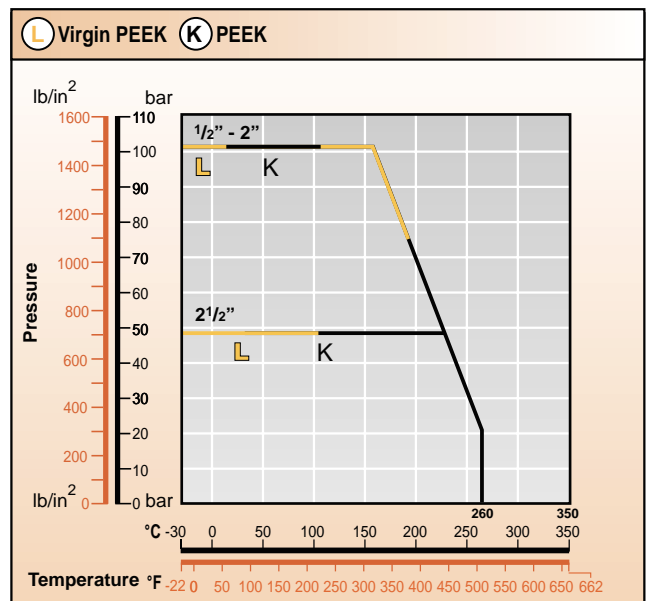
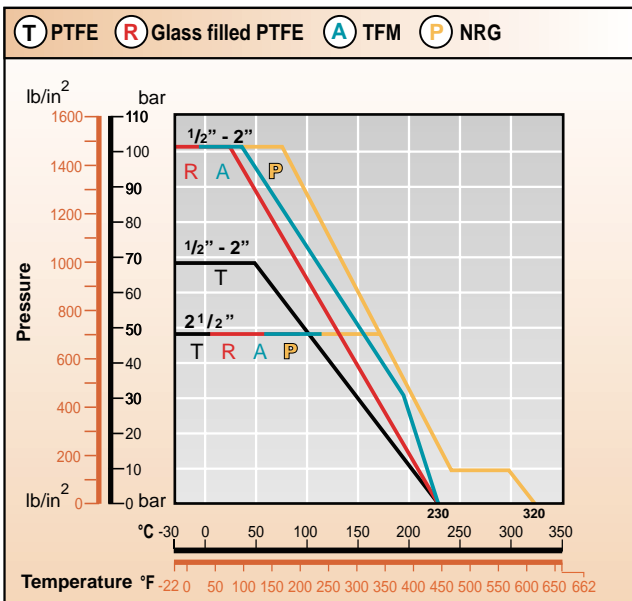

Valve Dimensions 1/2" - 2 1/2"

# Dimensions

1/2" - 2 1/2" (1/2" - 2" FB) 47P Series with ISO top

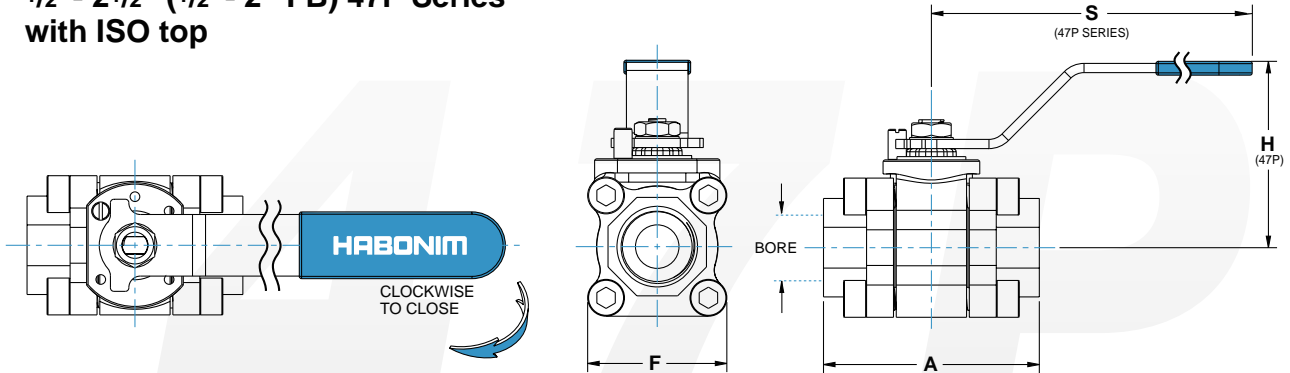

1/2" - 2" (1/2" - 1 1/2" FB) 46 Series

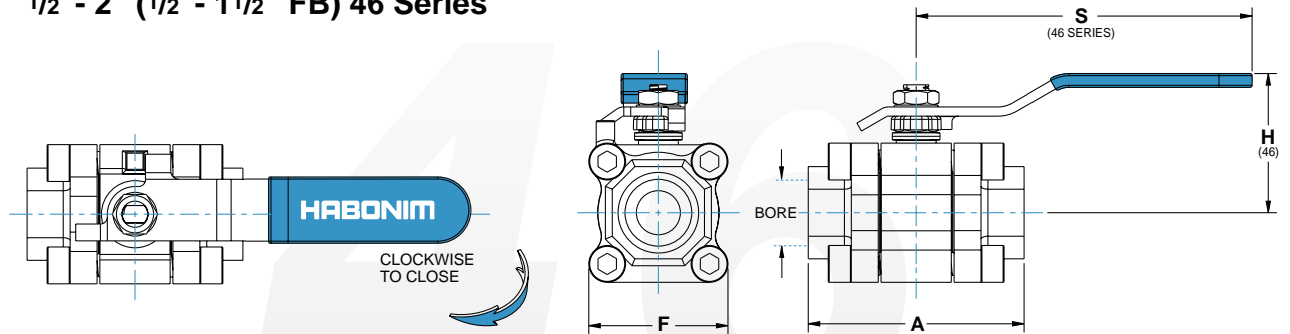

2 1/2" (2" FB) 47P Top (ISO 5211 F07)

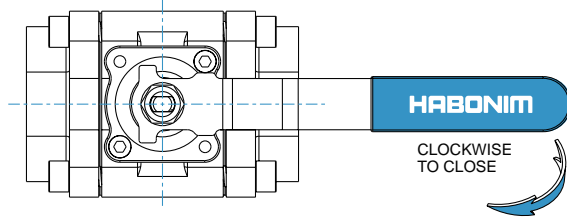

2 1/2" (2" FB) 46 Top (ISO 5211 F05)

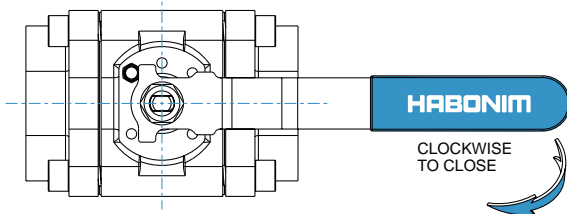

Valve Size	Unit	Valve Dimensions						
		Bore	A	F	H (47P)	H (46)	S (47P)	S (46)
1/4"	mm	11.15	66.0	47.0	61.5	44.5	150.0	114.0
	inch	0.44	2.598	1.85	2.421	1.752	5.906	4.49
3/8"	mm	11.15	66.0	47.0	61.5	44.5	150.0	114.0
	inch	0.44	2.598	1.85	2.421	1.752	5.906	4.49
1/2"	mm	11.15	66.0	47.0	61.5	44.5	150.0	114.0
	inch	0.44	2.598	1.85	2.421	1.752	5.906	4.49
3/4"	mm	14.3	71.0	53.7	63.9	46.7	150.0	114.0
	inch	0.56	2.795	2.114	2.516	1.838	5.609	4.49
1"	mm	20.6	93.7	63.7	79.4	60.0	187.0	146.0
	inch	0.81	3.689	2.507	3.126	2.362	7.362	5.75
1 1/4"	mm	25.4	108.0	71.7	84.1	64.8	187.0	146.0
	inch	1.0	4.252	2.822	3.311	2.551	7.362	5.75
1 1/2"	mm	31.8	115.5	86.7	97.0	76.5	237.0	178.0
	inch	1.25	4.547	3.413	3.819	3.011	9.331	7.0
2"	mm	38.1	128.0	96.9	101.8	81.2	237.0	178.0
	inch	1.5	5.039	3.815	4.008	3.197	9.331	7.0
2 1/2"	mm	50.8	158.0	108.0	115.1	112.1	237.0	287.0
	inch	2.0	6.22	4.25	4.53	4.413	9.331	11.30

For additional dimensions & details refer to Bulletin P-111

## Antistatic Firesafe Valves



The **AF** series, Anti Static Fire Safe valves are designed and tested to the requirements of API 607 4th Edition and to BS 6755 Part 2 specifications. The valves contain soft seat rings. In the event of fire, a secondary metallic machined fire lip on the end connector comes in contact with the ball and prevents leakage through the valve port. The anti static fire safe stem incorporates a machined fire lip, which will prevent leakage once the thrust seal is burned off. All **AF** valves are fitted with expanded graphite body seals and stem packing. All **AF** valves have 8 body bolts threaded to the body.

## Tongue & Groove Design

The Tongue & Groove design is used in all firesafe valves and is intended to allow full compression of the expanded graphite body seal and the alignment of the body to the ends. This is achieved by a specially machined tongue on the body with a mating groove in the end connector. The firesafe bodies and end connectors are not interchangeable with Habonim standard 47P/46 series bodies and ends.

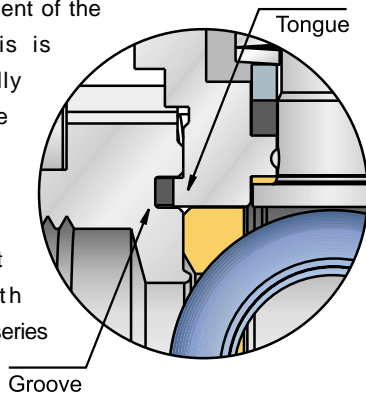

## Body Bolts

All Firesafe valves are fitted with 8 body bolts which are threaded to the body and are one size above the standard through body bolts. In the event of fire, these bolts will expand minimally and thus prevent external leakage from the body seals.

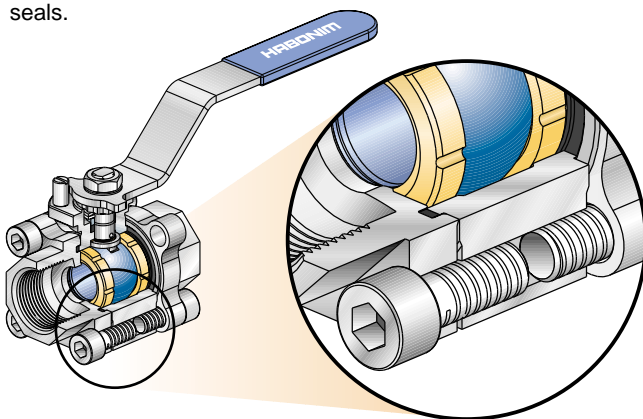

## Antistatic & Firesafe Stem

A precision machined blowout proof anti static fire safe stem is inserted into the body from within. The stem has a special anti static device and special machined fire lip for metal-to-metal contact sealing in the event of fire.

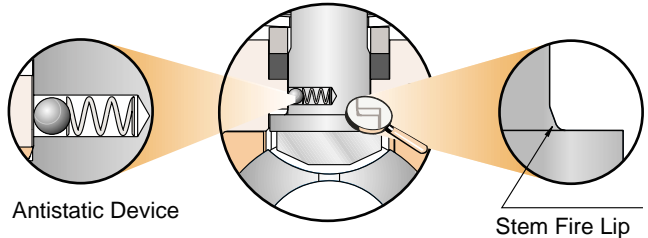

## In the event of FIRE

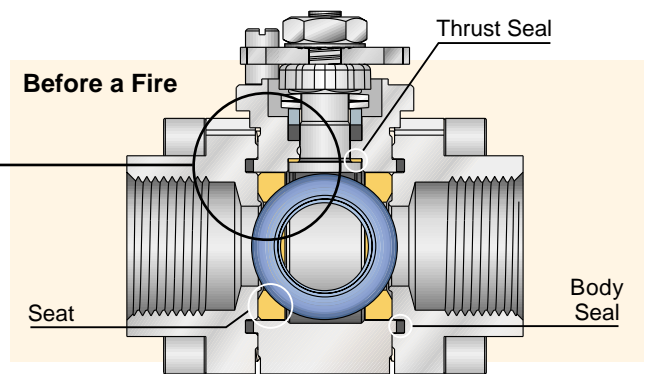

In the normal working condition the valves resilient seats with their special profile, provide bubble tight shutoff, while protecting the secondary metallic ring. The stem sealing is achieved by a resilient thrust seal and graphite gland packing. The valve graphite body seals are encapsulated and will not burn off.

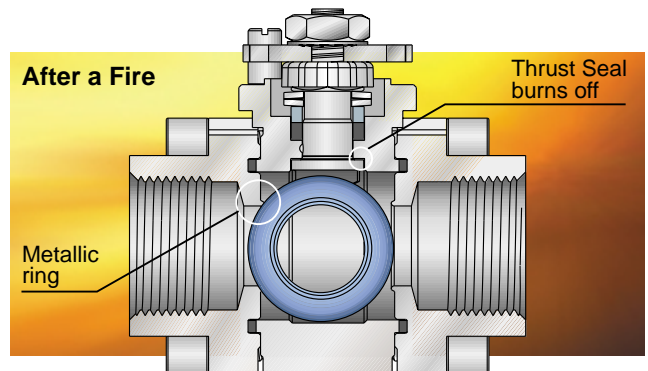

In the event of fire, the seats creep rapidly inward and tend to crawl between the ball and downstream port until they finally burn off. The specially machined secondary metallic ring prevents the seat from creeping inward and creates contact with the ball as it is pushed downstream, thus preventing leakage through the valve port. When the resilient thrust seal burns off, the stem is pushed upward by the growing internal pressure and the disk springs above, and its machined ring shaped surface prevents leakage.

TFM™ is a trademark of Dyneon, PEEK® is a trademark of VICTREX

In accordance with our policy to strive for continuous improvement of the product, we reserve the right to alter the dimensions, technical data and information included in this catalogue when required.